

BULLS EYE 2019

AFTERMARKET SEP 2019

IN THIS ISSUE:

- PRODUCT IN FOCUS
- **SPECIAL NOTICE**
- TECH TIPS
- WHY BUY
- NEW PRODUCTS & SUPERSESSIONS
- EMPLOYEE PROFILE

www.meritorpartsonline.com.au

RUN
WITH THE **BULL**

MERITOR



BULLS EYE 2019

PRODUCT IN FOCUS

MERITOR® T2000 AIR DRYERS AND CARTRIDGES

WHEN WAS THE LAST TIME YOU
REPLACED YOUR CARTRIDGE?

Meritor offer a full range
of air dryer cartridges to
suit your needs. A range of
aftermarket cartridges that
deliver efficiency and value
for customers while meeting
MERITOR quality standards.

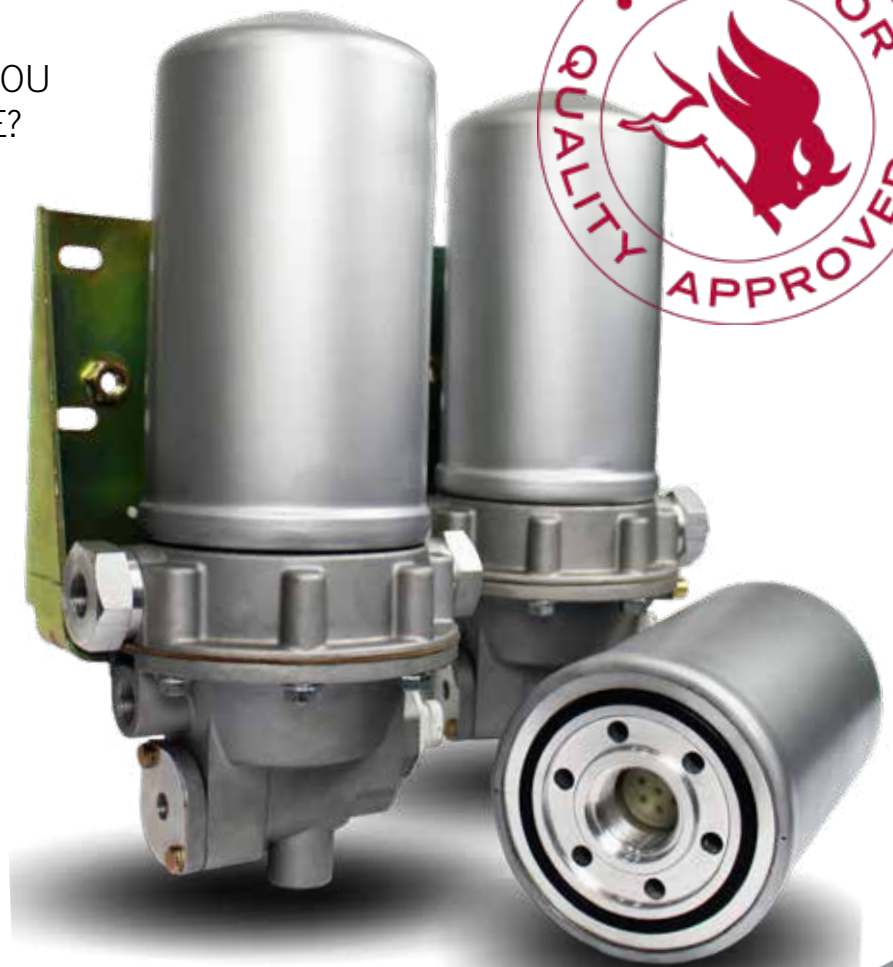

Find out more



RUN
WITH THE **BULL**



MERITOR

WWW.MERITORPARTSONLINE.COM.AU



BULLS EYE 2019

SPECIAL NOTICE MERITOR® READYSET™ KING PIN KIT

**AVAILABLE
NOW**



Meritor® ReadySet™ King Pin Kit Advantages:

- No reaming necessary on king pin bushings
- Built for strength with metal-to-metal componentry
- Manufactured for quality and durability

The Meritor® ReadySet No-Ream King Pin Kit is also easy to maintain, and is covered by Meritor's industry leading aftermarket 2-year warranty (parts only)

Find out more



RUN
WITH THE **BULL**



WWW.MERITORPARTSONLINE.COM.AU



BULLS EYE 2019

SPECIAL NOTICE MERITOR AFTERMARKET STOCKTAKE 2019



We wish to advise that Meritor Aftermarket will be undertaking stocktake on 19th and 20th of September 2019.

Please take note of the following dates and information: **ALL RETURNS SHOULD ARRIVE AT MERITOR NO LATER THAN Friday 13th of September 2019**

Parts Store will be closed from 12:00pm on Wednesday 18th September of 2019. Parts Store will re-open at 8:00am on Monday 23rd of September 2019. Only price and stock check enquiries will be accepted during the stocktake closure. Technical support staff will be limited.

Genuine VOR(Vehicle Off Road) cut-off date is Wednesday 18th of September at 10 am. Genuine VOR (Vehicle off Road) orders will continue to be processed during stocktake period.

We would like to take this opportunity to thank you for your cooperation in this matter.

Warm regards,

Meritor Aftermarket Team



BULLS EYE 2019

TECH TIPS

TIE ROD END: LINKAGE INSPECTION

- Lightly rock steering wheel, no movement to be in tapers.
- Wheel straight ahead, engine off, no force exerted on linkage by steering gear.
- Check joint by HAND in a push – pull motion in the direction of the ball stud axis.
- Must be held without twisting.
- **If motion is over 3 mm (1/8") Vehicle is to be taken out of service.**



Inspect for movement along vertical axis only.

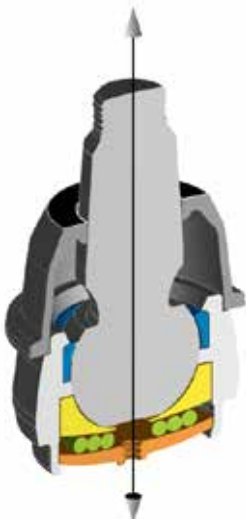

- If movement is less than 3 mm (1/8"), joint must be replaced as soon as possible.
- Do not use any leverage when checking.
- Any movement less than 3 mm (1/8") is a maintenance issue for the vehicle.
- Do not apply steering gear power to the joint when performing a check.



BULLS EYE 2019

TECH TIPS

TIE ROD END: LINKAGE INSPECTION

- Do not grease the tie rod assembly before inspection.
- Regular inspection and maintenance helps to minimise the effects of tie rod end wear.

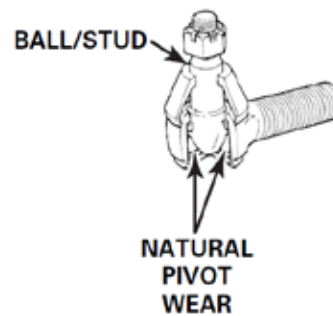

- Check boot for cracks, tears or other damage.

- Check that tie rod end is threaded correctly into the cross tube and installed deeper than the end of the cross tube slot.





BULLS EYE 2019

TECH TIPS

TIE ROD END: LINKAGE INSPECTION

CAUTION!

- Only use hands to check for movement.
- Using both hands, grasp the assembly end as close to the socket as possible, no more than 150 mm (6") from the end.
- Any movement, replace both tie rod ends.
- If movement is 3 mm (1/8") or more, remove vehicle from service and replace both tie rod ends immediately.

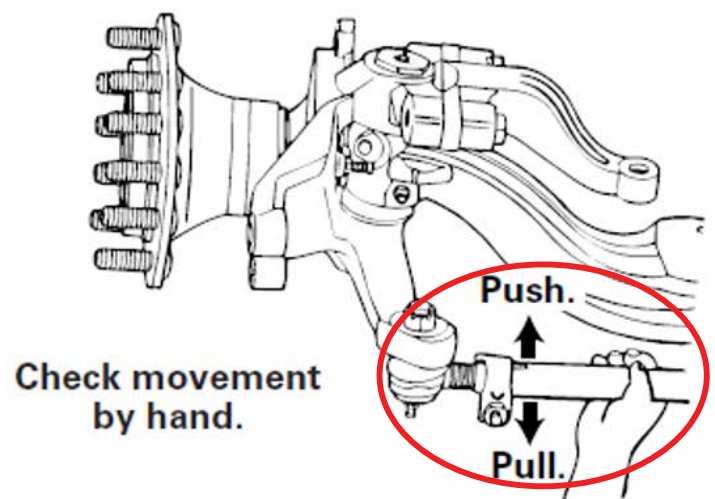

- Do not use excessive pressure when applying grease.
- All tie rod ends must purge grease from the boots

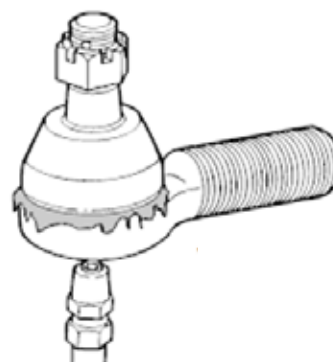

Find out more



RUN
WITH THE **BULL**



WWW.MERITORPARTSONLINE.COM.AU



BULLS EYE 2019

WHY BUY MERITOR® OPTI-CAST™ BRAKE DRUMS

FEATURES AND BENEFITS:

- High quality cast iron alloy to enhance heat dissipation equals longer friction life and improved drum durability
- Lightweight solution means reduced fuel consumption and cost savings
- Premium machine balanced for superior ride and handling
- Designed for both truck and trailer applications and compatible with popular wheel-end configurations

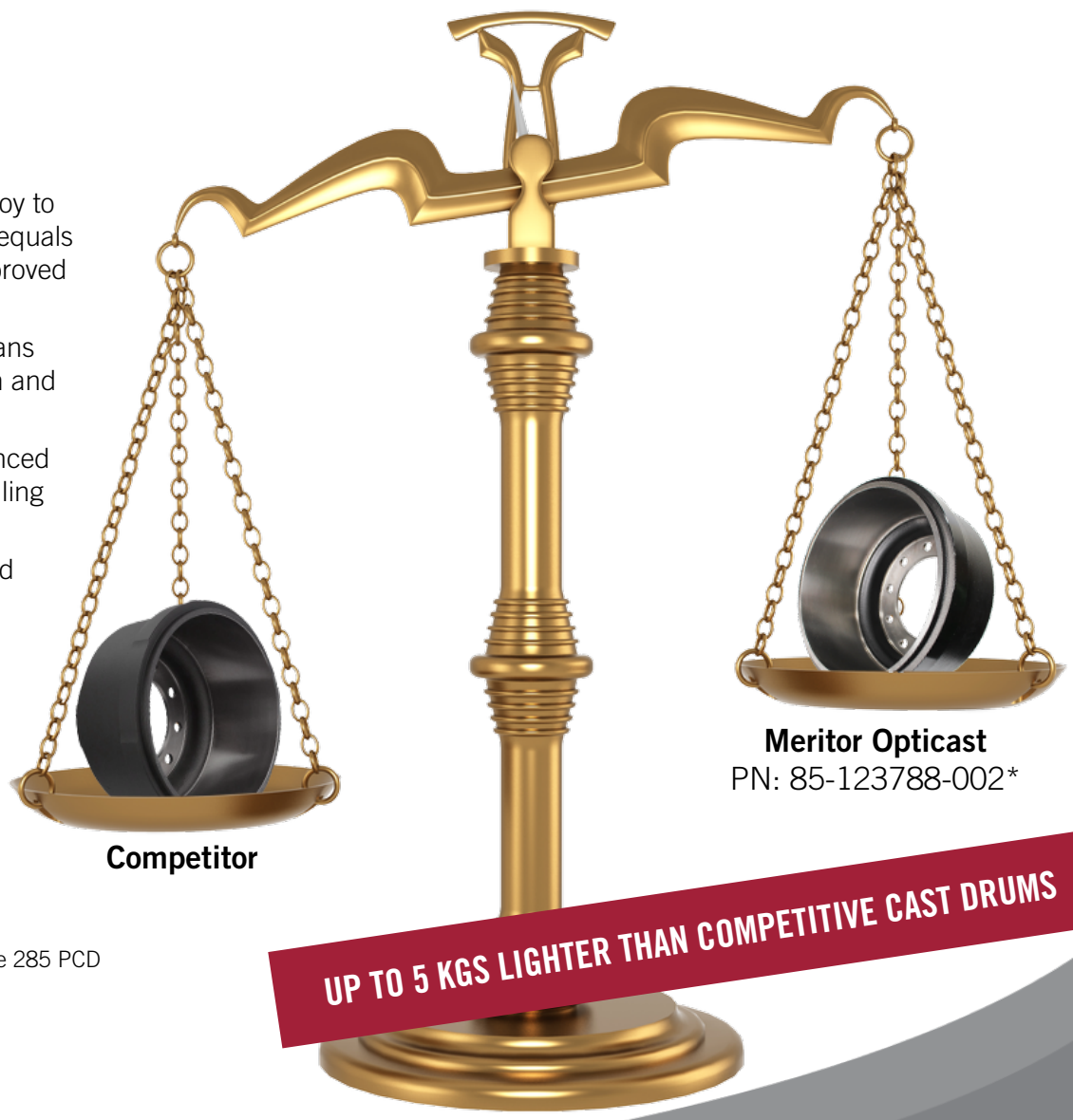

Competitor

Meritor Opticast
PN: 85-123788-002*

UP TO 5 KGS LIGHTER THAN COMPETITIVE CAST DRUMS

* Balanced, 16.5"x7" brake size 285 PCD

Find out more



BULLS EYE 2019

NEW PRODUCTS & SUPERSESSIONS

NEW PRODUCTS

NEW PART	DESCRIPTION	APPLICATION
T383299P6256	BRACKET BRAKE CHAMBER 56 DEG CBA 10.197 CBL 3G	Brakes Drive Axle
T383299Q6257	BRACKET BRAKE CHAMBER 56 DEG CBA 10.197 CBL 3G	Brakes Drive Axle

SUPERSESSIONS

OLD PART	DESCRIPTION	NEW PART
A13102C4293	TIE ROD ASSY 1.75" DI	R230576

All parts displayed in New Products & Supersessions will be available for immediate ordering. Lead times apply for the listed items. Not all parts are available to Independent Customers. Please contact Meritor Customer Service on (03) 8353 6050 for further information. For full list of supersessions, [CLICK HERE](#)

RUN
WITH THE **BULL**



WWW.MERITORPARTSONLINE.COM.AU



BULLS EYE 2019

EMPLOYEE PROFILE

LORA LU

ROLE AT MERITOR: Assistant Account Manager

YEAR JOINED MERITOR: 2019



1. WHAT IS YOUR BACKGROUND?

I am originally from China working in account management roles for about 6 years in Shanghai. I moved to Melbourne in 2017 to pursue my MBA (Executive) at RMIT. I am fascinated by business and I have a passion to work with people from different backgrounds. Although I have only worked at Meritor for three months, I have learned so much from my colleagues and my work.

2. TELL US A LITTLE BIT ABOUT YOUR MAIN JOB RESPONSIBILITIES.

My responsibilities as an assistant account manager are to support our sales team including the sales manager and regional managers with sales operations and to serve the current customers and potential customers here in Australia. Success to me is when the needs of sales team are satisfied, the customers are happy with our products and service and when the internal teams such as the supply chain and production teams get the support they need.

3. WHAT DO YOU ENJOY MOST ABOUT YOUR ROLE?

At Meritor people are experienced and highly dedicated to their roles. Many people have worked at Meritor for more than 10 years and have accumulated a vast amount of experience and business intuition. I enjoy working with and learning from my team members the most. I learn so much from them and am proud to be on their team.

4. WHAT IS YOUR BIGGEST CHALLENGE IN YOUR NEW ROLE AS ASSISTANT ACCOUNT MANAGER ?

My biggest challenge is that I feel a little intimidated by my highly productive colleagues. I want to ensure that I can contribute at the same level and it can be a bit overwhelming however I'm continuing to learn on a daily basis and it's becoming much easier for me.

5. WHAT ARE YOUR INTERESTS OUTSIDE WORK?

I enjoy gym classes, cooking, gardening, meditation and traveling. I am particularly interested in art exhibitions and attending cultural plays that inspire me to think deeper about the meaning of life.



MERITOR
RUN WITH THE BULL

MERITOR HEAVY VEHICLE SYSTEMS AUSTRALIA

Meritor Commercial Vehicle Aftermarket
50 Calarco Drive, Derrimut
Melbourne - VIC 3026 - Australia

Phone: (613) 8353 6050
cvaau.sales@meritor.com
www.meritorpartsonline.com.au