

BULLS EYE 2019

AFTERMARKET NOV 2019

IN THIS ISSUE:

- PRODUCT IN FOCUS
- SPECIAL NOTICE
- TECH TIPS
- WHY BUY
- NEW PRODUCTS & SUPERSESSIONS
- EMPLOYEE PROFILE

www.meritorpartsonline.com.au

RUN
WITH THE **BULL**

MERITOR



BULLS EYE 2019

PRODUCT IN FOCUS MERITOR GLADHANDS

DID YOU KNOW?

Gladhands are coupling devices used to connect the service and emergency air lines from the truck or tractor to the trailer.

The couplers have a rubber seal which prevents air from escaping. To connect the gladhands, the driver presses the two seals together with the couplers at a 90° angle to each other.

A turn of the glad hand attached to the hose will join and lock the couplers.



Ordered in convenient and sturdy Meritor display buckets - when sold as 75 pieces.



Find out more



RUN
WITH THE **BULL**



WWW.MERITORPARTSONLINE.COM.AU



BULLS EYE 2019

SPECIAL NOTICE MERITOR MUD FLAP

MERITOR AUSTRALIA IS DELIGHTED TO ANNOUNCE THE FIRST OF OUR VERY OWN MERITOR MUDFLAPS.

These mudflaps have been designed specifically to support all those loyal Meritor Australia customers who choose to Run with the Bull.

Available now in the industry's most popular size:
18"x24" (450mm x 610mm)

- Made in Australia
- UV-stabilised flexible polyvinyl compound (PVC)
- 100% recyclable



Part number: 2297B9414

HAVE YOU ORDERED YOURS?



**RUN
WITH THE BULL**



WWW.MERITORPARTSONLINE.COM.AU



BULLS EYE 2019

TECH TIPS

MERITOR® DRIVER-CONTROLLED DIFFERENTIAL LOCK (DCDL) INTER-AXLE DIFFERENTIAL (IAD) LOCK

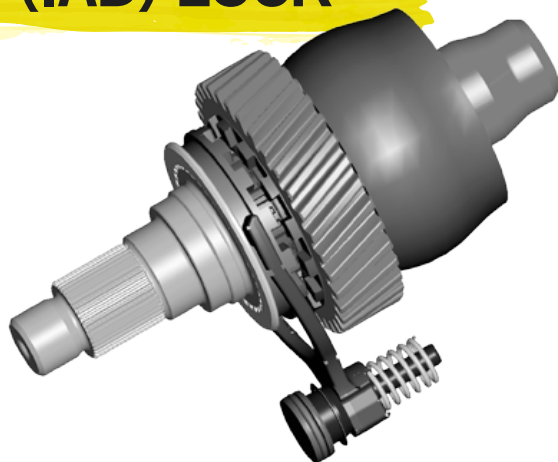

DRIVER-CONTROLLED DIFFERENTIAL LOCK (DCDL) INTER-AXLE DIFFERENTIAL (IAD) LOCK

Wheel Differential Function.

- Allows both wheel ends of an axle to receive equal torque from the driveline by "splitting" the torque between the two wheel ends
- Compensates for:
 - Speed difference between wheel ends that occurs when the vehicle is turning and the outside wheel rotates faster than the inside wheel
 - Tire mismatch
 - Uneven road conditions

Inter-Axle Differential Function.

- An inter-axle differential (IAD) works in a similar manner to the main differential except it splits the torque equally between the two axles of a tandem, rather than the two wheel ends of an axle.
- Allows for speed differences between the two axles of the tandem

Find out more



RUN
WITH THE **BULL**



WWW.MERITORPARTSONLINE.COM.AU



BULLS EYE 2019

WHY BUY WHEEL END BEARINGS

PREMIUM QUALITY BEARINGS FROM MERITOR, A NAME YOU KNOW AND TRUST.

Introducing Meritor premium bearings for optimum performance from a proven, steadfast source. You know Meritor for its longevity in the commercial vehicle market. Over 100 years of leadership in innovation, design and manufacturing means the best-quality products to meet your aftermarket replacement needs. Now you can depend on Meritor for all-makes premium tapered roller bearings for a cost-effective bearing solution. Designed for differentials, transmissions and wheel ends – including steer, drive and trailer axle applications – our comprehensive portfolio covers a wide range of bearing requirements.



- Manufactured using the same processes as Meritor production bearings
- Only high grade raw materials
- Less impurities for greater performance
- Through-hardening process for elevated tensile strength
- Precise internal geometry
 - Tighter accuracy and performance
- Traceability
 - Ability to trace a part from raw materials through production ensures product integrity

Find out more



**RUN
WITH THE BULL**



WWW.MERITORPARTSONLINE.COM.AU



BULLS EYE 2019

NEW PRODUCTS & SUPERSESSIONS

NEW PRODUCTS

PART	DESCRIPTION	APPLICATION
CP1350X	UNI JOINT PERMALUBE	Driveline
R203043	KIT KING PIN READYSET DANA I-132SG/I-140SG	Truck Front Axle
2210K7343	CAMSHAFT RH	Brakes
2210L7344	CAMSHAFT LH	Brakes
CB3100121XSA	BEARING CENTER SOLID SERIES 58WB, 72N, 17N, 82N	Driveline
R230577	TIE ROD ASSY 1.75" DIA	Truck Front Axle
R005798	STUD 1/2x2.238x13-20	Hardware Drive
R213012	BUSHING DRIVER KING PIN KIT READYSET	Truck Front Axle

SUPERSESSIONS

OLD PART	DESCRIPTION	NEW PART
E-8017AU	NUT 1.25-12UNF 2A H=1.7"	1227H554
E-8023AU	WASHER FLAT	1229A1561
E-8127AU	U BOLT AC6S	2297F9236
CB2108811X	BEARING CENTRE	CB3100121XSA
A23102L4380	TIE ROD ASSY 1.75" DIA	R230577
SC8191	STUD 1/2x2.238x13-20	R005798

All parts displayed in New Products & Supersessions will be available for immediate ordering. Lead times apply for the listed items. Not all parts are available to Independent Customers. Please contact Meritor Customer Service on (03) 8353 6050 for further information. For full list of supersessions, [CLICK HERE](#)

RUN
WITH THE **BULL**



WWW.MERITORPARTSONLINE.COM.AU



BULLS EYE 2019

EMPLOYEE PROFILE

AMANDA KELLY

ROLE AT MERITOR: Payroll Administrator

YEAR JOINED MERITOR: 2012



1. WHAT IS YOUR BACKGROUND?

Believe it or not but I use to be a Personal Trainer. After I decided that wasn't what I wanted, I moved into Accounts and finally into Payroll.

2. TELL US A LITTLE BIT ABOUT YOUR MAIN JOB RESPONSIBILITIES.

Ensuring payroll is done in a timely and efficient manner. Maintaining the payroll system. Answering all payroll related queries. Also assist with Invoicing.

3. WHAT DO YOU ENJOY MOST ABOUT YOUR ROLE?

I enjoy that I deal with every single person in this company Australia wide. My role isn't just limited to one or two departments.

4. WHAT IS YOUR BIGGEST CHALLENGE IN YOUR NEW ROLE AS PAYROLL ADMIN ?

Co-ordinating the priorities of an improved payroll function and budget constraints. And getting timesheets in on time!

5. WHAT ARE YOUR INTERESTS OUTSIDE WORK?

I enjoy catching up with friends and family, riding my Harley, travelling when I can and renovating my home.



MERITOR
RUN WITH THE BULL

MERITOR HEAVY VEHICLE SYSTEMS AUSTRALIA

Meritor Commercial Vehicle Aftermarket
50 Calarco Drive, Derrimut
Melbourne - VIC 3026 - Australia

Phone: (613) 8353 6050
cvaau.sales@meritor.com
www.meritorpartsonline.com.au