

BULLS EYE 2020



AFTERMARKET

FEB 2020

IN THIS ISSUE:

CLICK ON THE TITLE BELOW
TO BE SENT TO THE SPECIFIC
SUBJECT IN THIS ISSUE

- [SPECIAL NOTICE](#)
- [PRODUCT IN FOCUS](#)
- [TECH TIPS](#)
- [NEW PRODUCTS & SUPERSESSIONS](#)
- [EMPLOYEE PROFILE](#)



MERITOR[®]
RUN WITH THE BULL

BULLS EYE 2020



SPECIAL NOTICE

MERITOR AUSTRALIA IS TURNING 50

OVER 50 YEARS OF EXCELLENCE

AUSTRALIAN BUILT AXLES SINCE 1970

At Meritor we have a heritage of building world class axles that stretches back over 100 years. First as Timken Axle company and later as Rockwell Standard we've been at the forefront of designing and manufacturing axles that are trusted as the first choice of some of the biggest names in the truck world. Those names include Kenworth, Volvo, Western Star, Isuzu and IVECO.

This year in Australia, we're celebrating. It's been 50 years since the first Australian built axle rolled out of our Sunshine facility in Melbourne. While the axles that roll out today have changed significantly to deliver increased efficiency and cope with the higher payloads of the modern truck there's one thing that hasn't.

That's our commitment to support Australian built trucks with axles that are designed, tested and proven to perform under Australian conditions.

On behalf of the 100 Meritor Australia employees we'd like to thank you, the Meritor customer, for being a part of our success over the past 50 years.

We look forward to another 50 years here in Australia.

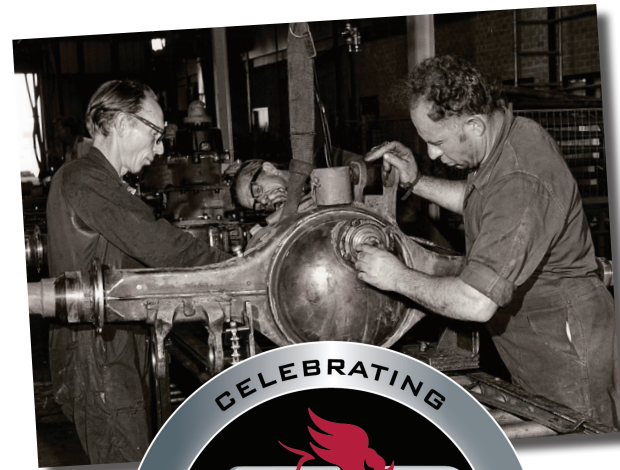

MERITOR
RUN WITH THE BULL

BULLS EYE 2020



PRODUCT IN FOCUS MERITOR AIR SPRINGS

NEW HENDRICKSON TRAILER AIR SPRING

MERITOR® is pleased to release a new air spring to complement the existing trailer range.

MAF9466 suits Hendrickson HA 400, 460 & 600 suspension (49048-002).

Find out more

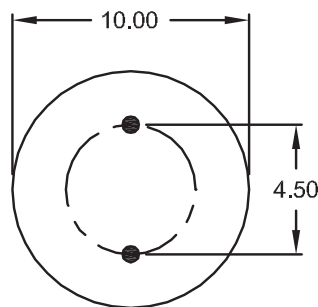
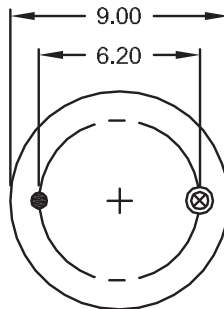
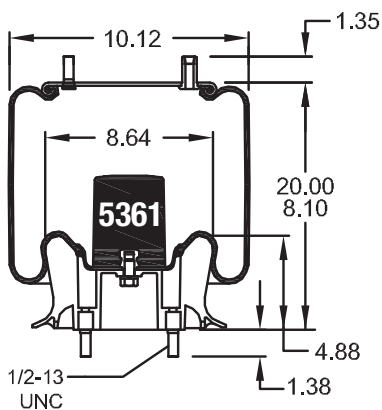

BULLS EYE 2020



TECH TIPS

INSTALLING A MULTIPLE-LIP SEAL

Today's TECH TIP is about Installing a **Multiple-Lip Seal** (MLS) onto Meritor single and tandem drive axles:

- 140, 160, 180 and 14X Series Single Drive Axles
- 140, 160, 180, 380, 13X and 14X Series
- Tandem Drive Axles
- MTC-4208/4210/4213 Transfer Cases



REMOVAL:

1. Wear safe eye protection.
2. Park the vehicle on a level surface. Set the parking brake. Block the wheels to prevent the vehicle from moving.
3. Use a jack to raise the vehicle so that the wheels to be serviced are off the ground. Support the vehicle with safety stands.
4. Disconnect the drive shafts.
5. Attach a flange bar or place a yoke bar over the input or output yoke to hold the yoke or flange while you remove the nut. Always use a flange or yoke bar during removal and installation of the flange yoke nut to prevent damage to the gearing.

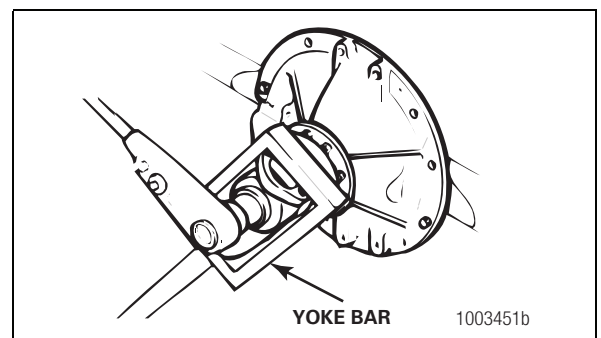

Find out more



BULLS EYE 2020



NEW PRODUCTS & SUPERSESSIONS

NEW PRODUCTS

PART	DESCRIPTION	APPLICATION
C3121L480S	Axle Housing	HOUSING ASSY - AXLE
E559.M	CVC GEARSET KIT 489 / 167E	GEARSET, VOLVO BUS
2803Q2851	SHIM SPACER	AXLE HARDWARE COMPONENT
2803R2852	SHIM SPACER	AXLE HARDWARE COMPONENT

SUPERSESSIONS

All parts displayed in New Products & Supersessions will be available for immediate ordering. Lead times apply for the listed items. Not all parts are available to Independent Customers. Please contact Meritor Customer Service on (03) 8353 6050 for further information. For full list of supersessions, [CLICK HERE](#)



BULLS EYE 2020



EMPLOYEE PROFILE

BRETT ZAHRA

YEAR OF JOIN: 2004

ROLE: Program Manager

1. What is your background?

I was a Warehouse / Logistics Manager at another organisation and having spent 6 years in this role I was looking for new challenges when an opportunity presented at Meritor. I entered Meritor in 2004 and over the course of 16 years have held many roles In Meritor ranging from Warehousing, Inventory up until recently (2019) was the Supply Chain / Logistics Manager for many years.

2. Tell us a little bit about your main job responsibilities.

Recently I took on a new challenge transitioning from Supply Chain / Logistics manager to Program Manager which encompasses a broad range of responsibilities across both OE (Original Equipment) and Aftermarket, leading and supporting our short and long term strategic outlook. This allows me to reach all corners of the business and use my knowledge and experience to support the united goals.

3. What do you enjoy most about your role?

It allows me to experience all parts of the business (OE & AFT) and learn more about our products, our customers and our people.

4. What is your biggest challenge in your new role as Program Manager?

Identifying improvements as we embark on our M2022 Strategy with new and exciting opportunities is highlighting the need to think differently, act differently and execute differently to achieve our desired outcome.

5. What are your interests outside work?

Outside of work, I enjoy DIY projects at home, riding motorbikes and thoroughbred racing. I have owned a few thoroughbreds in the past. I'm yet to have a potential Melbourne Cup runner but haven't quite given up on the dream.





MERITOR
RUN WITH THE BULL

MERITOR HEAVY VEHICLE SYSTEMS AUSTRALIA

Meritor Commercial Vehicle Aftermarket
50 Calarco Drive, Derrimut
Melbourne - VIC 3026 - Australia

Phone: (613) 8353 6050
cvaau.sales@meritor.com
www.meritorpartsonline.com.au