

Date: December 2017
Subject: Service Level Axle Housings for Isuzu Australia
Models: MS-11-165, MP-10-144, MP-10-14X, MR-10-144, MR-10-145, MP-11-165 and MR-11-165

Dear Customer,

This Product Information Letter provides Meritor Australia’s part numbers for service level axle housings to suit S-Cam (drum) brakes for Isuzu Australia.

All service housings include welded suspension brackets, welded brackets for supporting the brake chamber bracket (camshaft tube), studs for installing the differential carrier and housing plugs.

In addition, some service housings may also include a bolt-on bracket for ABS sensor installation.

Refer to the table below.

Axle Model	Suspension	Spring Saddle Brackets	Bolt-On ABS Bracket	Service Housing Wall Thickness (mm)	Service Level Housing Part Number	
MP-11-165	HAS	Not applicable	No	16	C27-3121B1952S	
MR-11-165			Yes	16	Z57-3121A1951P	
MS-11-165			No	12.7	C22-3121H1828S	
MP-10-14X				Yes	12.7	C24-3121G1827S
MP-10-144					12.7	Z79-3121B1952P
MR-10-145						
MR-10-144						
MP-11-165	6 ROD	Tall	No	16	Z79-3121A1951P	
MR-11-165		Tall	Yes	16	Z65-3121H1828P	
MP-10-14X		Short	No	12.7	Z83-3121G1827P	
MR-10-145		Short	Yes	12.7	C12-3121H1828S	
MR-10-144			Tall	No	12.7	C14-3121G1827S
MP-10-144		Yes		12.7	C38-3121A1951S	
MR-10-144						
MS-11-165	2 SPRING	Not applicable	Yes	16		

Notes:

- For ABS sensor installation, a bolt-on bracket (part number 2237-J-1440) and two long length cap screws (part number S-11018-1) are also included in the housing and should be installed on the housing flange and brake spider interface.
- For service housings to suit 6 Rod suspensions there are two different variations (tall or short) in spring saddle brackets. Refer to table below and figure 1 on page 2 to identify the correct brackets. Please note that dimension “X” is measured from the bracket surface and not the wear pads.

Bracket	Dimension “X”
Tall	118 mm
Short	108 mm

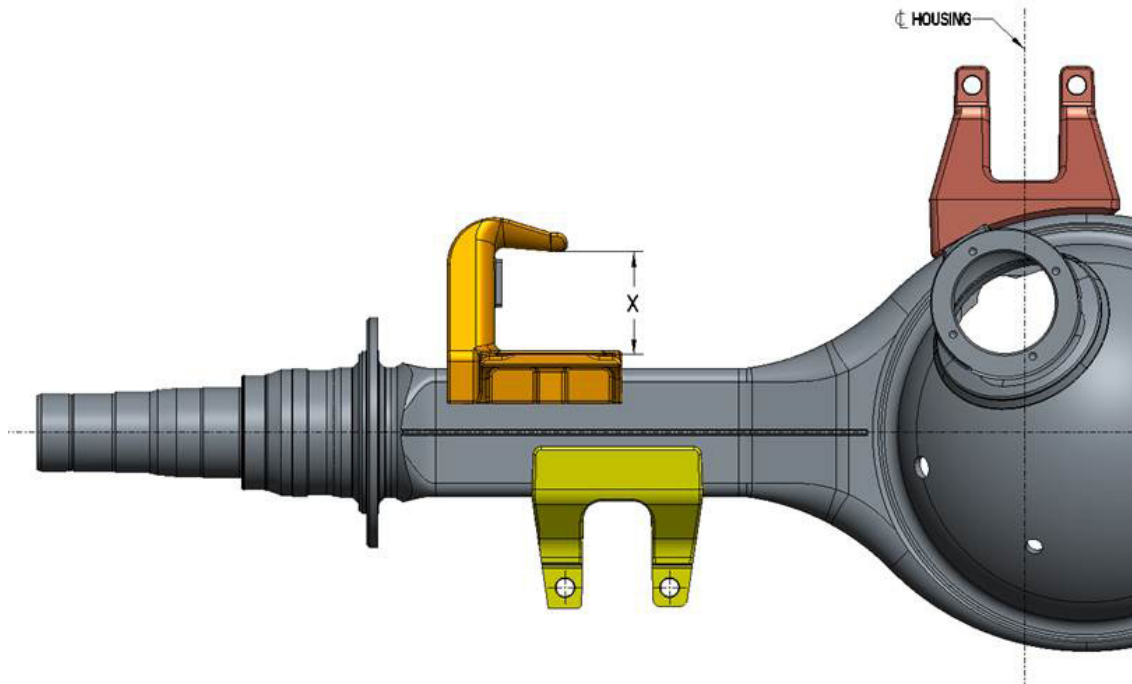

Figure 1: Illustration of spring saddle bracket to suit 6 Rod suspensions.

For any questions relating to the above, please contact a Meritor® Australia representative on +613-9300-5200.

**Issued by Product Engineering
Meritor HVSA Ltd**