



Date: February 2015

Subject: CTI Knuckle Options for MFS73 and FL941

Models: MFS73 AND FL941 Non Drive Front Steer Axle

Meritor® would like to advise on the release of new knuckle part numbers for the MFS73 AND FL941 steer axles, to suit the latest Central Tyre Inflation (CTI) system available from AIR CTI.

These new knuckles are available as an alternative to the current CTI knuckles offered for MFS73 and FL941, to suit the TIREBOSS™ system from Tire Pressure Control International Ltd (TPC).

The drilling and tapping of the knuckles for CTI systems is specific to each system, and the appropriate knuckle is required to suit the axle model and brand of CTI being fitted.

Different drillings and threads are offered to suit the specific CTI system

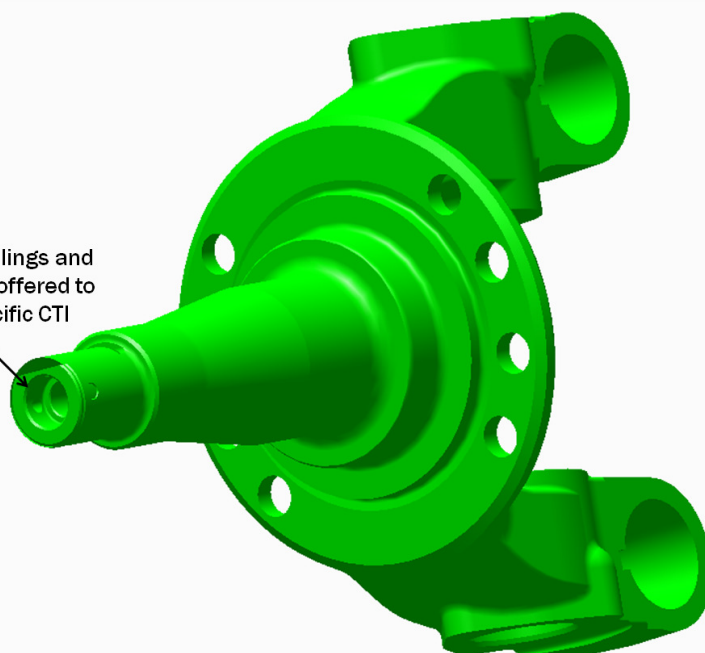



The following knuckle part numbers are available to suit each system;

<u>Axle Model</u>		<u>CTI System</u>	
		<u>TPC</u>	<u>AIR CTI</u>
MFS73	Left hand knuckle	A-3111-S-19A	A-3111-U-4753
	Right hand knuckle	A-3111-T-20A	A-3111-V-4754
FL941	Left hand knuckle	A-3111-N-4642	A-3111-B-4786
	Right hand knuckle	A-3111-P-4644	A-3111-C-4787

The gross axle weight rating (GAWR) and service guidelines for both axle models are not affected by the use of these new knuckles. Refer to the specific manufacturer for any service requirements of the CTI system.

If you have any questions relating to the above, please contact a Meritor® Australia representative on +613-9300-5200

**Issued by Product Engineering
Meritor HVSA Ltd**