

BULLS EYE 2018

AFTERMARKET
SEP 2018



MERITOR

IN THIS ISSUE:

PRODUCT IN FOCUS • TECH TIPS • NEW PRODUCTS • SUPERSESSIONS • SPECIAL NOTICE • Meritor Social

PRODUCT IN FOCUS - Brake Chambers

Safety should not be compromised and brake chambers are a vital part of any brake system.

When choosing Meritor brake chambers, the leader in brake components, you know you have made the right choice.

FEATURES AND BENEFITS

DESIGN

- Steel spring housing with aluminum centre section
- Designed for cost conscious customers
- Sealed spring brake (rear section) for O.H.S.

MAIN SPRING

- Corrosion protected standard performance main spring
- Designed and tested to meet performance requirements

CORROSION RESISTANCE

- Steel end caps are e-coated for excellent corrosion protection

QUALITY LEVEL

- Double o-ring and bushing structure

SIZE/STROKE

- Size options from 2424 to 3636
- Standard (2.5") stroke options



OPTIONS

- Includes release tool and holder
- Tandem, piggyback and service chamber
- Available with clevis

WARRANTY

- 1 year on-highway

www.meritorpartsonline.com.au

RUN
WITH THE BULL



BULLS EYE 2018

PRODUCT IN FOCUS - Brake Chambers

CHOOSE MERITOR® BRAKE CHAMBERS



Double O-rings and bushings structure provides the best leak protection and wear resistance

Premium diaphragm ensures 1.2 million chamber life cycles specifications

Premium diaphragm ensures 500 thousand parking life cycles

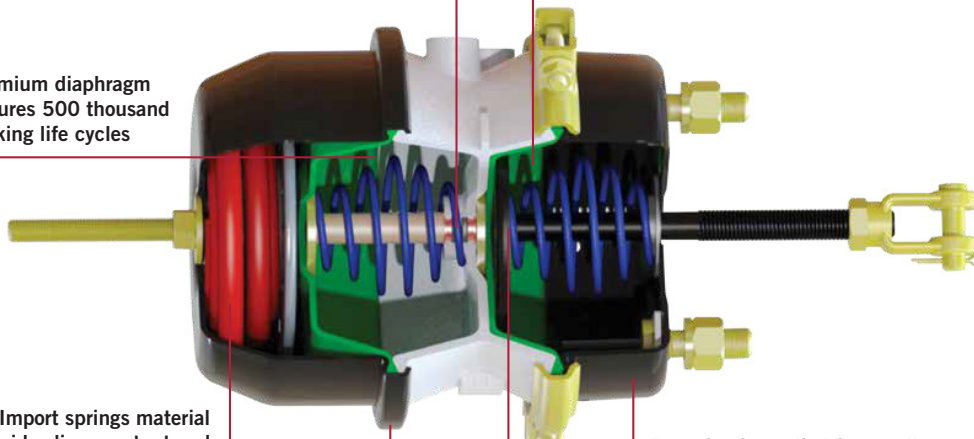

Import springs material provides linear output and 500 thousand parking life cycles specifications

E-coating is applied for excellent corrosion protection

Sealed spring brake (rear section) for O.H.S.

Drawn arc stud welding is applied for pushrod plate forming a bond that is stronger than the surrounding metal



MERITOR PART NUMBER	DESCRIPTION
R872424C	2424 BRAKE CHAMBER
R872430C	2430 BRAKE CHAMBER
R873030C	3030 BRAKE CHAMBER
R873636C	3636 BRAKE CHAMBER



www.meritorpartsonline.com.au

RUN WITH THE BULL



BULLS EYE 2018

TECH TIP - Tandem Axle

Do You Know Your Tandem Axle?

The Meritor Inter-Axle Differential (IAD) is a driver-controlled, air-actuated traction device that allows for speed differences between the forward and rear tandem axles while providing equal pulling power from each axle of the tandem.

By activating the IAD switch located in the vehicle dash, improved traction is provided for each axle. The Inter-Axle Differential (IAD) is more commonly known as a “Power Divider” or “Third” differential.

Operation Tips

- The IAD is driver controlled.
- The IAD switch should be in the “UNLOCK” position for normal operating conditions where there is good traction.
- Lock the IAD when approaching or anticipating any loss of traction or poor driving conditions to provide improved traction.
- Always unlock the IAD when the need for improved traction has passed or when the vehicle is on a good traction road or highway.
- After locking or unlocking the IAD, let up on the accelerator to provide an interruption in torque to the drivetrain.
- Do not actuate the IAD switch while one or more wheels are actually slipping, spinning or losing traction, or damage to the axle can result.
- Do not spin the wheels with the IAD unlocked, or damage to the axle components could result.

Driver Instructions

When encountering poor road or highway conditions where a decrease in traction is anticipated, follow the recommended procedures:

- Flip the IAD switch to “LOCK” position while maintaining constant vehicle speed.
- Let up momentarily on the accelerator. The differential lock will engage.
- Proceed to drive cautiously.

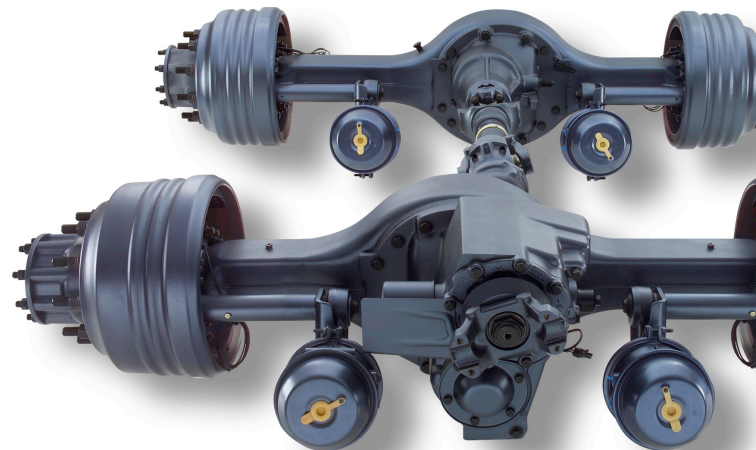

www.meritorpartsonline.com.au

**RUN
WITH THE BULL**



TECH TIP - Tandem Axle

Do You Know Your Tandem Axle?

Unlocking the IAD Switch

When poor road or highway conditions have passed, follow these steps to UNLOCK the IAD:

1. Flip the switch to the "UNLOCK" position while maintaining vehicle speed.
2. Let up momentarily on the accelerator. The differential lock will promptly disengage.
3. Resume a safe vehicle speed.

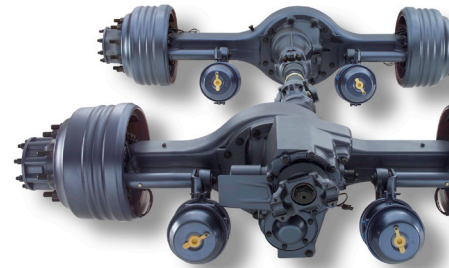

The operator-controlled IAD switch is on the dash and is marked LOCK and UNLOCK.

LOCK IAD at any speed EXCEPT when one or more wheels are slipping, spinning or losing traction.



UNLOCK = GOOD TRACTION

Permits differential action between axles for all normal driving.

LOCK = POOR TRACTION

Straight through positive power to both axles. No differential action.



How to Operate the Inter-Axle Differential (IAD) Also Called Third Differential or Power Divider

LOCK the IAD Switch When Poor Road Conditions Threaten to Minimize Traction

DO	unlock IAD for normal operating conditions when traction is good.
DO	lock IAD at any speed when you approach or anticipate poor road conditions where traction is at a minimum. IAD allows for speed differences between the forward and rear tandem axles, while providing pulling power from each axle of the tandem.
DO	let up on the accelerator to interrupt drivetrain torque after locking or unlocking IAD.
DO	unlock IAD when the need for improved traction has passed.
DON'T	lock IAD when one or more wheels are slipping, spinning or losing traction. You can damage an axle.
DON'T	spin the wheels with IAD unlocked. You can damage an axle.





BULLS EYE 2018

NEW PRODUCTS & SUPERSESSIONS

NEW PRODUCTS

PART NUMBER	DESCRIPTION
E-9878	DRAG LINK END LH
CPL10N2	KIT U JOINT L10 SERIES
MBD1162	BRAKE DRUM FRONT 335PCD 410X261
MBD1163	BRAKE DRUM DRIVE 335PCD 410X294
R201327	KING PIN KIT DANA E-1202I/W, E1322I/W, E1462I/W EZI-STEER
R202006	KING PIN KIT DANA E-1202I/W, E1322I/W, E1462I/W FASTSET (NO-REAM)

SUPERSESSIONS

OLD PART NUMBER	DESCRIPTION	NEW PART NUMBER
E255	KIT THRUST WASHER	E255-0
E-BC2424C	2424 BRAKE SPRING UNIT	R872424C
E-BC2430C	2430 BRAKE SPRING UNIT	R872430C
E-BC3030C	3030 BRAKE SPRING UNIT	R873030C
E-BC3636C	3636 BRAKE SPRING UNIT	R873636C

All parts displayed in New Products & Supersessions will be available for immediate ordering.
Lead times apply for the listed items.
Not all parts are available to Independent Customers.
Please contact Meritor Customer Service on (03) 8353 6050 for further information.
For full list of supersessions, [CLICK HERE](#)

www.meritorpartsonline.com.au

RUN
WITH THE **BULL**



BULLS EYE 2018

SPECIAL NOTICE - MERITOR Genuine

MERITOR GENUINE **BRAKE SHOE & HARDWARE KITS** TRUCK / TRAILER & BUS

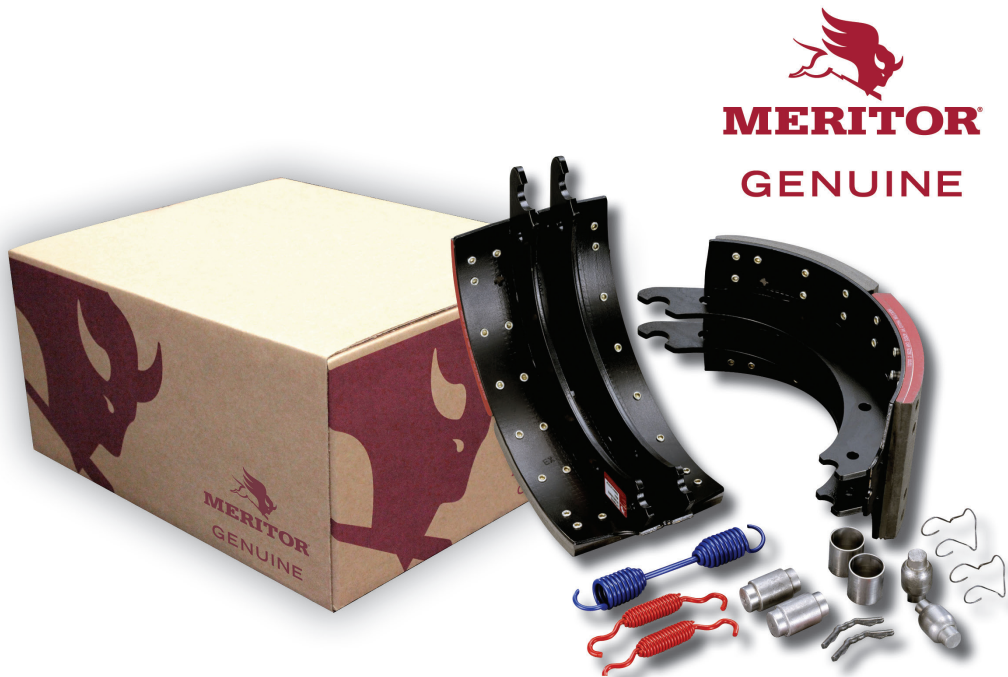

The Meritor Genuine range of brake shoe kits combine the convenience of all items in one kit and world leading technology, coupled with the commitment and certainty of uncompromising quality standards. And to reinforce this message we have stamped it on the box. The red edge, code and logo on each brake shoe kit is your sign that you are getting the very best aftermarket product available.

Meritor Genuine equals **Genuine Quality, Genuine Components** and **Genuine Value for money**. All Meritor Genuine Brake Shoe Kits come with tested and proven performance and value that have set a benchmark in braking engineering and manufacturing.

THE ONLY NAME IN BRAKES.

www.meritorpartsonline.com.au

**RUN
WITH THE BULL**



BULLS EYE 2018

Quick Reference Guide - MERITOR GENUINE

FMSI + SHOE TYPE	APPLICATION	SIZE	STANDARD GRADE	PREMIUM GRADE
1308, Q	MERITOR STEER "Q"	15" X 4" Q	KSMA2121308Q	KSMA3121308Q
1308, T	MERITOR STEER "T" BRAKE	15" X 4" T	KSMA2121308T	
4311, E	EATON DRIVE	16.5" X 7"	KSMA2124311E	KSMA3124311E
4514, Q	MERITOR STEER "Q"	16.5" X 6" Q	KSMA2124514Q	KSMA3124514Q
4515, F(Q)	FRUEHAUF/ SAF/ TMC	16.5" X 7" Q	KSMA2124515F3	
4515, F(P)	FRUEHAUF/ SAF/ TMC	16.5" X 7" P	KSMA2124515F	
4515, P	MERITOR DRIVE "P"	16.5" X 7" P	PKSMA2124515P	PKSMA3124515P
4515, PSS	MERITOR DRIVE "P" SEVERE SERVICE	16.5" X 7" P	PKSM2124515PSS	PKSMA3124515PSS
4515, Q	MERITOR DRIVE "Q"	16.5" X 7" Q	KSMA2124515Q	KSMA3124515Q
4524, Q	MERITOR STEER "Q"	16.5" X 5" Q	KSMA2124524Q	KSMA3124524Q
4702, QP	MERITOR STEER "Q PLUS"	15" X 4" Q PLUS	KSMA2124702QP	KSMA3124702QP
4707, QP	MERITOR DRIVE "Q PLUS"	16.5" X 7" Q PLUS	KSMA2124707QP	KSMA3124707QP
4709, ESI	EATON ES1 DRIVE	16.5" X 7"	KSMA2124709E1	KSMA3124709E1
4709, ESII	EATON ESII DRIVE	16.5" X 7"	KSMA2124709E2	
4710, QP	MERITOR STEER /TRAILER "Q PLUS"	15" X 8 5/8" Q PLUS	KSMA2124710QP	KSMA3124710QP
4711, QP	HENDRICKSON INTRAAX	16.5" X 8 5/8" Q PLUS	KSMA2124711QP	KSMA3124711QP
4715, QP	MERITOR STEER "Q PLUS"	16.5" X 6" Q PLUS	KSMA2124715QP	KSMA3124715QP
4719, ESII	EATON STEER BRAKE ESII	16.5" X 5"	KSMA2124719E	KSMA3124719E
4720, QP	MERITOR STEER "Q PLUS"	16.5" X 5" Q PLUS	KSMA2124720QP	KSMA3124720QP
4725, ESII	SPICER STEER BRAKE	16.5" X 6"	KSMA2124725R	KSMA3124725R
BC/36/1, B95	BPW BRAKE 95 BC/36/1	420MM X 180MM		MKSMG2ABC36/95
BC/36/1, NG	BPW NEW GEN BC36/1	420MM X 180MM		MKSMG2ABC36/NG
BC/37/1, B95	BPW BRAKE 95 BC/37/1	420MM X 200MM		MKSMG2ABC37



www.meritorpartsonline.com.au

**RUN
WITH THE BULL**



BULLS EYE 2018

MERITOR SOCIAL

Sunshine North Primary School



In line with its commitment to social responsibility, Meritor Australia has been actively partnering with and supporting their local primary school, Sunshine North Primary for the last 5 years.

Sunshine North Primary is situated in the western suburbs of Melbourne and is a socially disadvantaged school* with a high immigrant/refugee population.

The partnering occurs in 3 ways:

1. Due to economic issues, many children arrive at school without having had breakfast. Each Wednesday, 2 Meritor volunteers attend the school to help prepare and serve breakfast to the children. This not only ensures a nutritious start to the day, but also allows Meritor employees the opportunity to connect with the children and provide positive adult role modelling. Meritor also supplies financial support for the breakfast materials.

2. Each year the school conducts a 3 day school camp for their senior students (years 3, 4, 5 and 6). Traditionally there have been a number of children who have not been able to attend for a variety of reasons including financial, lack of confidence, etc. It has always been a concern to the School Principal that these children miss out and have to remain at the school. In 2017, financial support provided by Meritor and its employees allowed the school to hire mini buses to take these children to camp for 1 day to participate in the camp experience and spend

the day with their classmates undertaking camp activities. As a result of this support, 2017 was the first year in the school's history that every eligible child was able to attend camp and, further, many of those children have now developed the confidence to attend the full 3 day camp in 2018. This support will continue in 2018 and beyond.

3. As part of their cultural development program, the school has a music program where the children learn to dance, play musical instruments, etc. Often they don't have an audience to play to except themselves and their parents. Several times per year groups of schoolchildren performers attend the 2 Meritor sites in Melbourne to perform at communication sessions to the delight of our employees. The children then stay for a BBQ lunch with the Meritor team.

Meritor has also been pleased to be able to provide additional support as the need arises, including providing financial support for football jumpers and books for the library.

*310 students, over 200 families, over 140 families on EMA (Education Maintenance Allowance), 70 children are in single parent families, SFO .79 (a most highly disadvantaged school), 34 different languages spoken.

www.meritorpartsonline.com.au

**RUN
WITH THE BULL**

